



HVAC Products

SUBMITTAL

Mar 2018

308 SERIES DUAL EXPANSION JOINT 2" TRAVEL W/150# PLATE FLANGES

PROJECT:	
CUSTOMER:	
ENGINEER:	
ARCHITECT:	

MATERIALS OF CONSTRUCTION	
'A' PIPE SCH 40:	CARBON STEEL
'B' CAPSULE:	T-304 STN STL
'C' BASE PLATE:	CARBON STEEL
'D' PLATE FLANGES:	CARBON STEEL

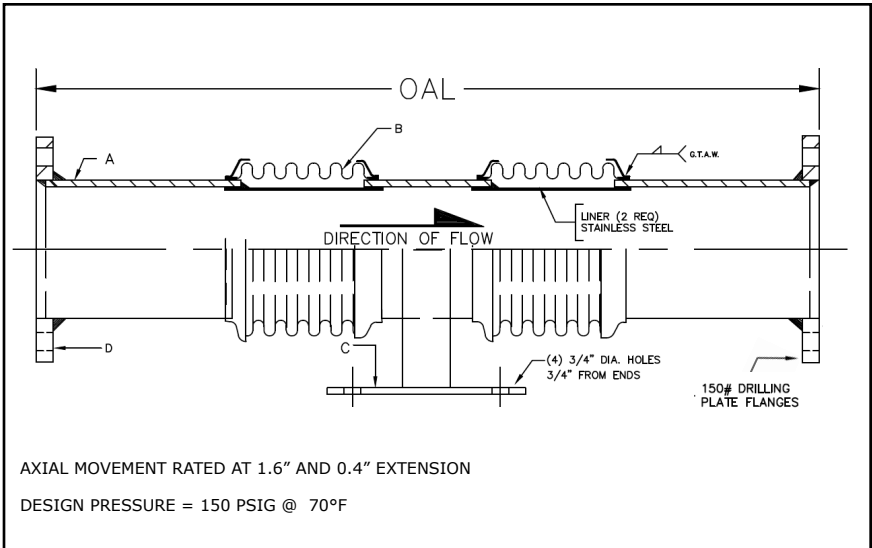

QTY	ID # OR TAG #	DIA (IN)	KEFLEX PART #	OAL	AXIAL FORCE TO COMPRESS (LBS)	WEIGHT (LBS)	3D Model (.stp)
		2"	F020M308DB1502	19"	100	24	
		2 1/2"	F024M308DB1502	19"	200	24	
		3"	F030M308DB1502	19"	150	44	
		4"	F040M308DB1502	19"	400	61	
		5"	F050M308DB1502	19"	225	76	
		6"	F060M308DB1502	19"	250	90	
		8"	F080M308DB1502	19"	400	130	
		10"	F100M308DB1502	19"	600	165	
		12"	F120M308DB1502	19"	350	229	

Typical Installation

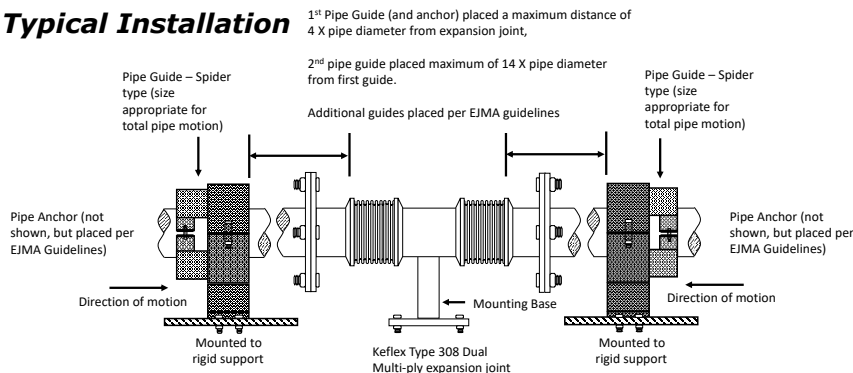

IMPORTANT LINKS

BROCHURE:	
INSTALLATION INSTRUCTIONS:	
TECHNICAL DATA:	
WEBSITE:	FLEX-WELD.COM



MADE IN THE USA

**1425 LAKE AVE
WOODSTOCK, IL 60098
800-323-6893**